

## Genus one 1-bridge knots and Dunwoody manifolds\*

Luigi Grasselli and Michele Mulazzani

(Communicated by Karl Strambach)

**Abstract.** In this paper we show that all 3-manifolds of a family introduced by M. J. Dunwoody are cyclic coverings of lens spaces (possibly  $S^3$ ), branched over genus one 1-bridge knots. As a consequence, we give a positive answer to the Dunwoody conjecture that all the elements of a wide subclass are cyclic coverings of  $S^3$  branched over a knot. Moreover, we show that all branched cyclic coverings of a 2-bridge knot belong to this subclass; this implies that the fundamental group of each branched cyclic covering of a 2-bridge knot admits a geometric cyclic presentation.

1991 Mathematics Subject Classification: 57M12, 57M25; 20F05, 57M05.

### 1 Introduction and preliminaries

The problem of determining if a balanced presentation of a group is geometric (i.e. induced by a Heegaard diagram of a closed orientable 3-manifold) is quite important within geometric topology and has been deeply investigated by many authors (see [9], [22], [25], [26], [27], [28], [33]); further, the connections between branched cyclic coverings of links and cyclic presentations of groups induced by suitable Heegaard diagrams have been recently pointed out in several papers (see [1], [3], [4], [6], [11], [12], [16], [18], [17], [20], [34]). In order to investigate these connections, M. J. Dunwoody introduces in [6] a class of planar, 3-regular graphs endowed with a cyclic symmetry. Each graph is defined by a 6-tuple of integers; if this 6-tuple satisfies suitable conditions (admissible 6-tuple), the graph uniquely defines a Heegaard diagram such that the presentation of the fundamental group of the represented manifold is cyclic. This construction gives rise to a wide class of closed orientable 3-manifolds (Dunwoody manifolds), depending on 6-tuples of integers and admitting geometric cyclic presentations for their fundamental groups. Our main result is that each Dunwoody manifold is a cyclic covering of a lens space (possibly the 3-sphere), branched over

---

\* Work performed under the auspices of G.N.S.A.G.A. of C.N.R. of Italy and supported by MURST and by the University of Bologna, funds for selected research topics.

a genus one 1-bridge knot. As a direct consequence, the Dunwoody manifolds belonging to a wide subclass are proved to be cyclic coverings of  $\mathbf{S}^3$ , branched over suitable knots, thus giving a positive answer to a conjecture of Dunwoody [6]. Moreover, we show that all branched cyclic coverings of knots with classical (i.e. genus zero) bridge number two belong to this subclass; as a corollary, the fundamental group of each branched cyclic covering of a 2-bridge knot admits a geometric cyclic presentation.

For the theory of Heegaard splittings of 3-manifolds, and in particular for Singer moves on Heegaard diagrams realizing the homeomorphism of the represented manifolds, we refer to [13] and [31]. For the theory of cyclically presented groups, we refer to [15].

We recall that a finite balanced presentation of a group  $\langle x_1, \dots, x_n \mid r_1, \dots, r_n \rangle$  is said to be a *cyclic presentation* if there exists a word  $w$  in the free group  $F_n$  generated by  $x_1, \dots, x_n$  such that the relators of the presentation are  $r_k = \theta_n^{k-1}(w)$ ,  $k = 1, \dots, n$ , where  $\theta_n : F_n \rightarrow F_n$  denotes the automorphism defined by  $\theta_n(x_i) = x_{i+1} \pmod{n}$ ,  $i = 1, \dots, n$ . Let us denote this cyclic presentation (and the related group) by the symbol  $G_n(w)$ , so that:

$$G_n(w) = \langle x_1, x_2, \dots, x_n \mid w, \theta_n(w), \dots, \theta_n^{n-1}(w) \rangle.$$

A group is said to be cyclically presented if it admits a cyclic presentation. We recall that the *exponent-sum* of a word  $w \in F_n$  is the integer  $\varepsilon_w$  given by the sum of the exponents of its letters; in other terms,  $\varepsilon_w = v(w)$  where  $v : F_n \rightarrow \mathbf{Z}$  is the homomorphism defined by  $v(x_i) = 1$  for each  $1 \leq i \leq n$ .

Following [10], we recall the definition of genus  $g$  bridge number of a link, which is a generalization of the classical concept of bridge number for links in  $\mathbf{S}^3$  (see [5]).

A set of mutually disjoint arcs  $\{t_1, \dots, t_n\}$  properly embedded in a handlebody  $U$  is trivial if there is a set of mutually disjoint discs  $D = \{D_1, \dots, D_n\}$  such that  $t_i \cap D_i = t_i \cap \partial D_i = t_i$ ,  $t_i \cap D_j = \emptyset$  and  $\partial D_i - t_i \subset \partial U$  for  $1 \leq i, j \leq n$  and  $i \neq j$ . Let  $U_1$  and  $U_2$  be the two handlebodies of a Heegaard splitting of the closed orientable 3-manifold  $M$  and let  $T$  be their common surface: a link  $L$  in  $M$  is in  $n$ -bridge position with respect to  $T$  if  $L$  intersects  $T$  transversally and if the set of arcs  $L \cap U_i$  has  $n$  components and is trivial both in  $U_1$  and in  $U_2$ . A link in 1-bridge position is obviously a knot.

The genus  $g$  bridge number of a link  $L$  in  $M$ ,  $b_g(L)$ , is the smallest integer  $n$  for which  $L$  is in  $n$ -bridge position with respect to some genus  $g$  Heegaard surface in  $M$ . If the genus  $g$  bridge number of a link  $L$  is  $b$ , we say that  $L$  is a genus  $g$   $b$ -bridge link or simply a  $(g, b)$ -link. Of course, the genus  $g$  bridge number of a link in a manifold of Heegaard genus  $g'$  is defined only for  $g \geq g'$  and the genus 0 bridge number of a link in  $\mathbf{S}^3$  is the classical bridge number. Moreover, a  $(g, 1)$ -link is a knot, for each  $g \geq 0$ .

In what follows, we shall deal with  $(1, 1)$ -knots, i.e. knots in  $\mathbf{S}^3$  or in lens spaces. This class of knots is very important in the light of some results and conjectures involving Dehn surgery on knots (see [2], [7], [8], [35], [36], [37]). Notice that the class of  $(1, 1)$ -knots in  $\mathbf{S}^3$  contains all torus knots (trivially) and all 2-bridge knots (i.e.  $(0, 2)$ -knots) [23].

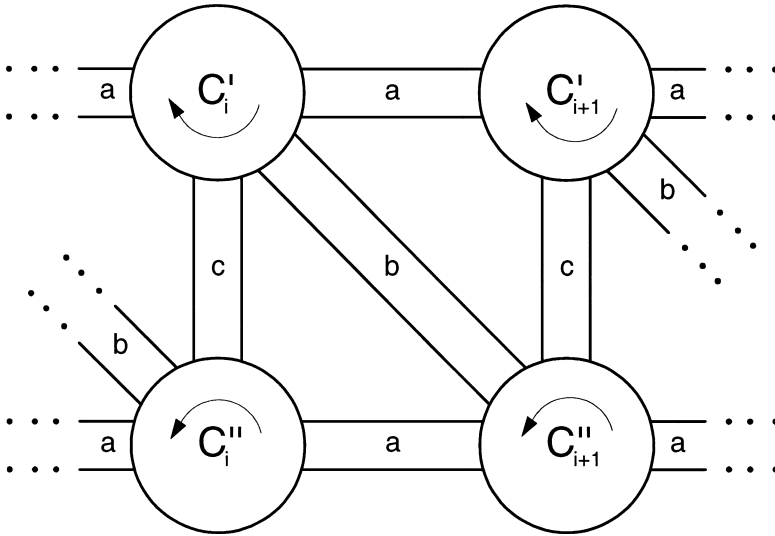

Fig. 1. The graph  $\Gamma$ .

**2 Dunwoody manifolds**

Let us sketch now the construction of Dunwoody manifolds given in [6]. Let  $a, b, c, n$  be integers such that  $n > 0, a, b, c \geq 0$  and  $a + b + c > 0$ . Let  $\Gamma = \Gamma(a, b, c, n)$  be the planar regular trivalent graph drawn in Figure 1.

It contains  $n$  upper cycles  $C'_1, \dots, C'_n$  and  $n$  lower cycles  $C''_1, \dots, C''_n$ , each having  $d = 2a + b + c$  vertices. For each  $i = 1, \dots, n$ , the cycle  $C'_i$  (resp.  $C''_i$ ) is connected to the cycle  $C'_{i+1}$  (resp.  $C''_{i+1}$ ) by  $a$  parallel arcs, to the cycle  $C''_i$  by  $c$  parallel arcs and to the cycle  $C''_{i+1}$  by  $b$  parallel arcs (assume  $n + 1 = 1$ ). We set  $\mathcal{C}' = \{C'_1, \dots, C'_n\}$  and  $\mathcal{C}'' = \{C''_1, \dots, C''_n\}$ . Moreover, denote by  $A'$  (resp.  $A''$ ) the set of the arcs of  $\Gamma$  belonging to a cycle of  $\mathcal{C}'$  (resp.  $\mathcal{C}''$ ) and by  $A$  the set of the other arcs of the graph. The one-point compactification of the plane leads to a 2-cell embedding of the graph  $\Gamma$  in  $S^2$ ; it is evident that the graph is invariant with respect to a rotation  $\rho_n$  of the sphere by  $2\pi/n$  radians along a suitable axis intersecting  $S^2$  in two points not belonging to the graph. Obviously,  $\rho_n$  sends  $C'_i$  to  $C'_{i+1}$  and  $C''_i$  to  $C''_{i+1} \pmod n$ , for each  $i = 1, \dots, n$ .

By cutting the sphere along all  $C'_i$  and  $C''_i$  and by removing the interior of the corresponding discs, we obtain a sphere with  $2n$  holes. Let now  $r$  and  $s$  be two new integers; give a clockwise (resp. counterclockwise) orientation to the cycles of  $\mathcal{C}'$  (resp. of  $\mathcal{C}''$ ) and label their vertices from 1 to  $d$ , in accordance with these orientations (see Figure 2) so that:

- the vertex 1 of each  $C'_i$  is the endpoint of the first arc of  $A$  connecting  $C'_i$  with  $C'_{i+1}$ ;
- the vertex  $1-r \pmod d$  of each  $C''_i$  is the endpoint of the first arc of  $A$  connecting  $C''_i$  with  $C''_{i+1}$ .

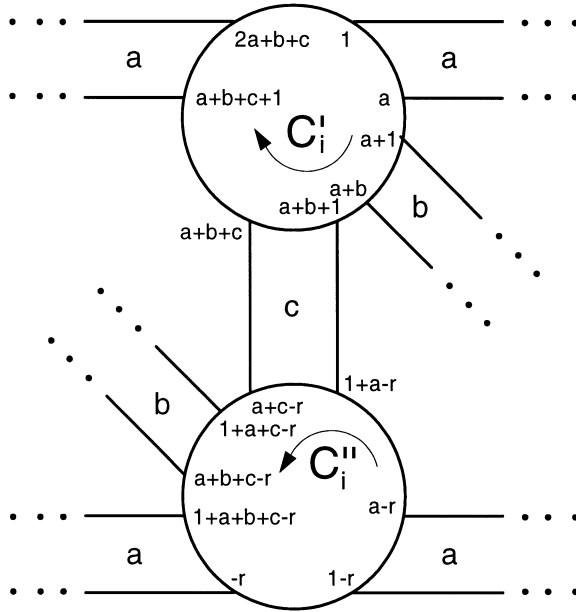

Fig. 2.

Then glue the cycle  $C'_i$  with the cycle  $C''_{i-s} \pmod n$  so that equally labelled vertices are identified together.

It is evident by construction that the integers  $r$  and  $s$  can be taken  $\pmod d$  and  $\pmod n$  respectively. Denote by  $\mathcal{S}$  the set of all the 6-tuples  $(a, b, c, n, r, s) \in \mathbf{Z}^6$  such that  $n > 0, a, b, c \geq 0$  and  $a + b + c > 0$ .

The described gluing gives rise to an orientable surface  $T_n$  of genus  $n$  and the  $nd$  arcs belonging to  $A$  are pairwise connected through their endpoints, realizing  $m$  cycles  $D_1, \dots, D_m$  on  $T_n$ . It is straightforward that the cut of  $T_n$  along the  $n$  cycles  $C_i = C'_i = C''_{i-s}$  does not disconnect the surface. Set  $\mathcal{C} = \{C_1, \dots, C_n\}$  and  $\mathcal{D} = \{D_1, \dots, D_m\}$ .

If  $m = n$  and if the cut along the cycles of  $\mathcal{D}$  does not disconnect  $T_n$ , then the two systems of meridian curves  $\mathcal{C}$  and  $\mathcal{D}$  in  $T_n$  represent a genus  $n$  Heegaard diagram of a closed orientable 3-manifold, which is completely determined by the 6-tuple. Each manifold arising in this way is called a *Dunwoody manifold*.

Thus, we define to be *admissible* the 6-tuples  $(a, b, c, n, r, s)$  of  $\mathcal{S}$  satisfying the following conditions:

- (1) the set  $\mathcal{D}$  contains exactly  $n$  cycles;
- (2) the surface  $T_n$  is not disconnected by the cut along the cycles of  $\mathcal{D}$ .

The “open” Heegaard diagram  $\Gamma$  and the Dunwoody manifold associated to the admissible 6-tuple  $\sigma$  will be denoted by  $H(\sigma)$  and  $M(\sigma)$  respectively.

**Remark 1.** It is easy to see that not all the 6-tuples in  $\mathcal{S}$  are admissible. For example, the 6-tuples  $(a, 0, a, 1, a, 0)$ , with  $a \geq 1$ , give rise to exactly  $a$  cycles in  $\mathcal{D}$ ; thus, they are not admissible if  $a > 1$ . The 6-tuples  $(1, 0, c, 1, 2, 0)$  are not admissible if  $c$  is even, since, in this case, we obtain exactly one cycle  $D_1$ , but the cut along it disconnects the torus  $T_1$ .

Consider now a 6-tuple  $\sigma \in \mathcal{S}$ . The graph  $\Gamma$  becomes, via the gluing quotient map, a regular 4-valent graph denoted by  $\Gamma'$  embedded in  $T_n$ . Its vertices are the intersection points of the spaces  $\Omega = \bigcup_{i=1}^n C_i$  and  $\Lambda = \bigcup_{j=1}^m D_j$ ; hence they inherit the labelling of the corresponding glued vertices of  $\Gamma$ . Since the gluing of the cycles of  $\mathcal{C}'$  and  $\mathcal{C}''$  is invariant with respect to the rotation  $\rho_n$ , the group  $\mathcal{G}_n = \langle \rho_n \rangle$  naturally induces a cyclic action of order  $n$  on  $T_n$  such that the quotient  $T_1 = T_n/\mathcal{G}_n$  is homeomorphic to a torus. The labelling of the vertices of  $\Gamma'$  is invariant under the rotation  $\rho_n$  and  $\rho_n(C_i) = C_{i+1} \pmod n$ . We are going to show that, if the 6-tuple is admissible, this last property also holds for the cycles of  $\mathcal{D}$ .

**Lemma 1.** a) *Let  $\sigma = (a, b, c, n, r, s)$  be an admissible 6-tuple. Then  $\rho_n$  induces a cyclic permutation on the curves of  $\mathcal{D}$ . Thus, if  $D$  is a cycle of  $\mathcal{D}$ , then  $\mathcal{D} = \{\rho_n^{k-1}(D) \mid k = 1, \dots, n\}$ .*

b) *If  $(a, b, c, n, r, s)$  is admissible, then also  $(a, b, c, 1, r, 0)$  is admissible and the Heegaard diagram  $H(a, b, c, 1, r, 0)$  is the quotient of the Heegaard diagram  $H(a, b, c, n, r, s)$  with respect to  $\mathcal{G}_n$ .*

*Proof.* a) First of all, note that  $\rho_n(\Lambda) = \Lambda$ ; thus the group  $\mathcal{G}_n$  also acts on the spaces  $T_n - \Lambda$  and  $\Lambda$  (and hence on the set  $\mathcal{D}$ ). If the 6-tuple  $\sigma$  is admissible, then  $T_n - \Lambda$  is connected, and hence the quotient  $(T_n - \Lambda)/\mathcal{G}_n = T_n/\mathcal{G}_n - \Lambda/\mathcal{G}_n$  must be connected too. This implies that  $\Lambda/\mathcal{G}_n$  has a unique connected component. Since  $\Lambda$  has exactly  $n$  connected components, the cyclic group  $\mathcal{G}_n$  of order  $n$  defines a simply transitive cyclic action on the cycles of  $\mathcal{D}$ .

b) Let  $C, D \subset T_1$  the two curves  $C = \Omega/\mathcal{G}_n$  and  $D = \Lambda/\mathcal{G}_n$ . Then, the two systems of curves  $\mathcal{C} = \{C\}$  and  $\mathcal{D} = \{D\}$  on  $T_1$  define a Heegaard diagram of genus one. The graph  $\Gamma_1$  corresponding to  $\sigma_1 = (a, b, c, 1, r, 0)$  is the quotient of the graph  $\Gamma_n$  corresponding to  $\sigma = (a, b, c, n, r, s)$ , with respect to  $\mathcal{G}_n$ . Moreover, the gluings on  $\Gamma_n$  are invariant with respect to  $\rho_n$ . Therefore, the gluings on  $\Gamma_1$  give rise to the Heegaard diagram above. This show that the 6-tuple  $\sigma_1$  is admissible and obviously  $H(a, b, c, 1, r, 0)$  is the quotient of  $H(a, b, c, n, r, s)$  with respect to  $\mathcal{G}_n$ .  $\square$

**Remark 2.** More generally, given two positive integer  $n$  and  $n'$  such that  $n'$  divides  $n$ , if  $(a, b, c, r, n, s)$  is admissible, then  $(a, b, c, r, n', b)$  is admissible too. Moreover, the Heegaard diagram  $H(a, b, c, r, n', b)$  is the quotient of  $H(a, b, c, r, n, b)$  with respect to the action of a cyclic group of order  $n/n'$ .

It is easy to see that, for admissible 6-tuples, each cycle in  $\mathcal{D}$  contains  $d$  vertices with different labels and is composed by exactly  $d$  arcs of  $\Gamma$  (in fact,  $2a$  horizontal arcs,  $b$  oblique arcs and  $c$  vertical arcs).

An important consequence of point a) of Lemma 1 is that, if  $\sigma$  is an admissible 6-tuple, the presentation of the fundamental group of  $M(\sigma)$  induced by the Heegaard diagram  $H(\sigma)$  is cyclic.

To see this, let  $v$  be the vertex belonging to the cycle  $C_1$  and labelled by  $a + b + 1$ ; denote by  $D_1$  the curve of  $\mathcal{D}$  containing  $v$  and by  $v'$  the vertex of  $C'_1$  corresponding to  $v$ . Orient the arc  $e' \in A$  of the graph  $\Gamma$  containing  $v'$  so that  $v'$  is its first endpoint and orient the curve  $D_1$  in accordance with the orientation of this arc. Now, set  $D_k = \rho_n^{k-1}(D_1)$ , for each  $k = 1, \dots, n$ ; the orientation on  $D_1$  induces, via  $\rho_n$ , an orientation also on these curves. Moreover, these orientation on the cycles of  $\mathcal{D}$  induce an orientation on the arcs of the graph  $\Gamma$  belonging to  $A$ . By orienting the arcs of  $C'$  and  $C''$  in accordance with the fixed orientations of the cycles  $C'_i$  and  $C''_i$ , the graph  $\Gamma$  becomes an oriented graph, whose orientation is invariant under the action of the group  $\mathcal{G}_n$ . Let us define to be *canonical* this orientation of  $\Gamma$ .

Let now  $w \in F_n$  be the word obtained by reading the oriented arcs  $e_1 = e', e_2, \dots, e_d$  of  $\Gamma$  corresponding to the oriented cycle  $D_1$ , starting from the vertex  $v'$ . The letters of  $w$  are in one-to-one correspondence with the oriented arcs  $e_h$ ; more precisely, the letter of  $w$  corresponding to  $e_h$  is  $x_i$  if  $e_h$  comes out from the cycle  $C'_i$  and is  $x_i^{-1}$  if  $e_h$  comes out from the cycle  $C''_{i-s}$ . Note that the word  $\theta_n^{k-1}(w)$  in the cyclic presentation  $G_n(w)$  is obtained by reading the cycle  $D_k$  along the given orientation, for  $1 \leq k \leq n$  (roughly speaking, the automorphism  $\theta_n$  is “geometrically” realized by  $\rho_n$ ).

This proves that each admissible 6-tuple  $\sigma$  uniquely defines, via the associated Heegaard diagram  $H(\sigma)$ , a word  $w = w(\sigma)$  and a cyclic presentation  $G_n(w)$  for the fundamental group of the Dunwoody manifold  $M(\sigma)$ . Note that the sequence of the exponents in the word  $w(\sigma)$ , and hence its exponent-sum  $\varepsilon_{w(\sigma)}$ , only depends on the integers  $a, b, c, r$ .

Let us consider now the Dunwoody manifolds  $M(a, b, c, n, r, s)$  with  $n = 1$  (and hence  $s = 0$ ), which arises from a genus one Heegaard diagram.

**Proposition 2.** *Let  $(a, b, c, 1, r, 0)$  be an admissible 6-tuple and let  $w = w(a, b, c, 1, r, 0)$  be the associated word. Then the Dunwoody manifold  $M(a, b, c, 1, r, 0)$  is homeomorphic to:*

- i)  $\mathbf{S}^3$ , if  $\varepsilon_w = \pm 1$ ;
- ii)  $\mathbf{S}^1 \times \mathbf{S}^2$ , if  $\varepsilon_w = 0$ ;
- iii) a lens space  $L(\alpha, \beta)$  with  $\alpha = |\varepsilon_w|$ , if  $|\varepsilon_w| > 1$ .

*Proof.* From  $n = 1$  we obtain  $w \in F_1 \cong \mathbf{Z} \cong \langle x | \emptyset \rangle$ . Thus,  $\pi_1(M) \cong G_1(w) \cong \langle x | x^{\varepsilon_w} \rangle \cong \mathbf{Z}_{|\varepsilon_w|}$ .  $\square$

**Example 1.** The Dunwoody manifolds  $M(0, 0, 1, 1, 0, 0)$ ,  $M(1, 0, 0, 1, 1, 0)$  and  $M(0, 0, c, 1, r, 0)$ , with  $c, r$  coprime, are homeomorphic to  $\mathbf{S}^3$ ,  $\mathbf{S}^1 \times \mathbf{S}^2$  and to the lens space  $L(c, r)$ , respectively. Moreover, all lens spaces also arise with  $a \neq 0$ ; in fact, for each  $a > 0$ ,  $M(a, 0, c, 1, a, 0)$  is homeomorphic with the lens space  $L(c, a)$ , if  $a$  and  $c$

are coprime, since it is easy to see that  $H(a, 0, c, 1, a, 0)$  can be transformed into the canonical genus one Heegaard diagram of  $L(c, a)$  by Singer moves of type IB.

Let us see now how the admissibility conditions for the 6-tuples of  $\mathcal{S}$  can be given in terms of labelling of the vertices of  $\Gamma'$ , belonging to the curve  $D_1 \in \mathcal{D}$ . With this aim, consider the following properties for a 6-tuple  $\sigma \in \mathcal{S}$ :

- (i') the set of the labels of the vertices belonging to the cycle  $D_1$  is the set of all integers from 1 to  $d$ ;
- (ii') the vertices of the cycle  $D_1$  have different labels.

It is easy to see that, if a 6-tuple  $\sigma \in \mathcal{S}$  is admissible, then it satisfies (i') and (ii'). On the other side, if a 6-tuple  $\sigma \in \mathcal{S}$  satisfies (i') and (ii'), then the curves  $\rho_n^{k-1}(D_1) \in \mathcal{D}$ , with  $k = 1, \dots, n$ , which are all different from each other, are precisely the curves of  $\mathcal{D}$ . Thus,  $\mathcal{D}$  has exactly  $n$  curves and they are cyclically permuted by  $\rho_n$ . However, this does not imply that  $\sigma$  is admissible; for example, the 6-tuple  $(1, 0, 2, 1, 2, 0)$  satisfies (i') and (ii'), but it is not admissible (see Remark 1). Note that, for  $n = 1$ , property (ii') always holds, while condition (i') holds if and only if  $\mathcal{D}$  has a unique cycle.

If a 6-tuple satisfies property (i'), then  $\mathcal{G}_n$  acts transitively (not necessarily simply) on  $\mathcal{D}$ , and hence it is possible to induce an orientation (which is still said to be canonical) on the cycles of  $\mathcal{D}$  and on the graph  $\Gamma$ , by extending, via  $\rho_n$ , the orientation of  $D_1$  to the other cycles of  $\mathcal{D}$ .

Property (i') implies that the cycles of  $\mathcal{D}$  naturally induce a cyclic permutation on the set  $\mathcal{N} = \{1, \dots, d\}$  of the vertex labels. In fact, by walking along these canonically oriented cycles, starting from an arbitrary vertex  $\bar{v}$  labelled  $j$ , one sequentially meets  $d$  vertices (whose labels are different from each other), and then a new vertex  $\bar{v}'$  labelled  $j$  which can be different from  $\bar{v}$ . The sequence of the labellings of these  $d$  consecutive vertices defines the cyclic permutation on  $\mathcal{N}$ . Further, each cycle of  $\mathcal{D}$  precisely contains  $d' = ld$  arcs, with  $l \geq 1$ , and  $l = 1$  if and only if the 6-tuple satisfies (ii') too. Moreover, property (i') is independent from the integers  $n$  and  $s$ ; hence, given two 6-tuples  $\sigma = (a, b, c, n, r, s)$  and  $\sigma' = (a, b, c, n', r, s)$ , then  $\sigma$  satisfies (i') if and only if  $\sigma'$  satisfies (i').

Let now  $\sigma$  be a 6-tuple satisfying (i') and suppose that  $\Gamma$  is canonically oriented. An arc of  $\Gamma$  belonging to  $A$  is said to be of type I if it is oriented from a cycle of  $\mathcal{C}'$  to a cycle of  $\mathcal{C}''$ , of type II if it is oriented from a cycle of  $\mathcal{C}''$  to a cycle of  $\mathcal{C}'$  and of type III otherwise (it joins cycles of  $\mathcal{C}'$  or cycles of  $\mathcal{C}''$ ). Moreover, the arc is said to be of type I' if it is oriented from a cycle  $C'_i$  (resp.  $C''_i$ ) to a cycle  $C'_{i+1}$  (resp.  $C''_{i+1}$ ), of type II' if it is oriented from a cycle  $C'_{i+1}$  (resp.  $C''_{i+1}$ ) to a cycle  $C'_i$  (resp.  $C''_i$ ) and of type III' otherwise (it joins  $C'_i$  with  $C''_i$ ). Let  $\Delta$  be the set of the first  $d$  arcs of  $D_1$ , following the canonical orientation, starting from the arc coming out from the vertex  $v'$  of  $C'_1$  labelled  $a + b + 1$ . Obviously, the set  $\Delta$  contains all the arcs of  $D_1$  if and only if the 6-tuple  $\sigma$  also satisfies (ii').

Now, denote by  $p'_\sigma$  (resp.  $p''_\sigma$ ) the number of the arcs of type I (resp. of type II) of  $\Delta$  and set  $p_\sigma = p'_\sigma - p''_\sigma$ . Similarly, denote by  $q'_\sigma$  (resp.  $q''_\sigma$ ) the number of the arcs of

type I' (resp. of type II') of  $\Delta$  and set  $q_\sigma = q'_\sigma - q''_\sigma$ . Note that  $p_\sigma$  has the same parity of  $b + c$  and  $q_\sigma$  has the same parity of  $2a + b$  and hence of  $b$ . It is evident that  $p_\sigma$  and  $q_\sigma$  only depend on the integers  $a, b, c, r$ .

The integers  $p_\sigma$  and  $q_\sigma$  give an useful tool for verifying condition (ii'). In fact, suppose to walk along the canonically oriented cycle  $D_j$  of  $\mathcal{D}$ , starting from a vertex  $\bar{v}$  and let  $C_i$  be the cycle of  $\mathcal{C}$  containing  $\bar{v}$ . If  $\bar{v}'$  is the first vertex with the same label of  $\bar{v}$  and if  $C_{i'}$  is the cycle of  $\mathcal{C}$  containing  $\bar{v}'$ , we have  $i' = i + q_\sigma + sp_\sigma$ . Thus, the cycle  $D_j$  contains  $d$  arcs if and only if  $q_\sigma + sp_\sigma \equiv 0 \pmod{n}$ . This proves that the 6-tuple satisfies (ii'). Thus, (i') and (ii') are respectively, in a different language, conditions (i) and (ii) of Theorem 2 of [6], which gives a necessary and sufficient condition for a 6-tuple to be admissible when  $d$  is odd. In fact, we have the following result:

**Lemma 3** ([6], Theorem 2). *Let  $\sigma = (a, b, c, n, r, s)$  be a 6-tuple with  $d = 2a + b + c$  odd. Then  $\sigma$  is admissible if and only if it satisfies (i') and (ii').*

**Remark 3.** This result does not hold when  $d$  is even. In fact, the 6-tuples  $(1, 0, c, 1, 2, 0)$ , with  $c$  even, satisfy (i') and (ii'), but they are not admissible, as pointed out in Remark 1.

An immediate consequence of Lemma 3 is the following result:

**Corollary 4.** *Let  $\sigma = (a, b, c, n, r, s)$  be a 6-tuple with  $d = 2a + b + c$  odd and  $n = 1$ . Then  $\sigma$  is admissible if and only if  $\mathcal{D}$  has a unique cycle.*

*Proof.* If  $\sigma$  is admissible, then it is straightforward that  $\mathcal{D}$  has a unique cycle. Vice versa, if  $\mathcal{D}$  has a unique cycle, then (i') holds. Since  $n = 1$  implies (ii'), the result is a direct consequence of the above lemma.  $\square$

The parameter  $p_\sigma$  associated to an admissible 6-tuple  $\sigma$  is strictly related to the word  $w(\sigma)$  associated to  $\sigma$ . In fact, we have:

**Lemma 5.** *Let  $\sigma = (a, b, c, n, r, s)$  be an admissible 6-tuple,  $w = w(\sigma)$  the associated word and  $\varepsilon_w$  its exponent-sum. Then*

$$p_\sigma = \varepsilon_w.$$

*Proof.* Since  $\sigma$  is admissible, the arcs of  $\Delta$  are precisely the arcs of  $D_1$ . Let  $e_1, e_2, \dots, e_d$  be the sequence of these arcs, following the canonical orientation on  $D_1$ , and let  $w = \prod_{h=1}^d x_{i_h}^{u_h}$ , with  $u_h \in \{+1, -1\}$ . We have:  $\varepsilon_w = \sum_{h=1}^d u_h = 1/2 \sum_{h=1}^d (u_h + u_{h+1})$ , where  $d + 1 = 1$ . Since  $u_h + u_{h+1} = +2$  if  $e_h$  is of type I,  $u_h + u_{h+1} = -2$  if  $e_h$  is of type II and  $u_h + u_{h+1} = 0$  if  $e_h$  is of type III, the result immediately follows.  $\square$

In [6] Dunwoody investigates a wide subclass of manifolds  $M(\sigma)$  such that  $p_\sigma = \pm 1$  and he conjectures that all the elements of this subclass are cyclic coverings of  $\mathbf{S}^3$  branched over knots. In the next chapter this conjecture will be proved as a corollary of a more general theorem.



### 3 Main results

The following theorem is the main result of this paper and shows how the cyclic action on the Heegaard diagrams naturally extends to a cyclic action on the associated Dunwoody manifolds, which turn out to be cyclic coverings of  $S^3$  or of lens spaces, branched over suitable knots.

**Theorem 6.** *Let  $\sigma = (a, b, c, n, r, s)$  be an admissible 6-tuple, with  $n > 1$ . Then the Dunwoody manifold  $M = M(a, b, c, n, r, s)$  is the  $n$ -fold cyclic covering of the manifold  $M' = M(a, b, c, 1, r, 0)$ , branched over a genus one 1-bridge knot  $K = K(a, b, c, r)$  only depending on the integers  $a, b, c, r$ . Further,  $M'$  is homeomorphic to:*

- i)  $S^3$ , if  $p_\sigma = \pm 1$ ,
- ii)  $S^1 \times S^2$ , if  $p_\sigma = 0$ ,
- iii) a lens space  $L(\alpha, \beta)$  with  $\alpha = |p_\sigma|$ , if  $|p_\sigma| > 1$ .

*Proof.* Since the two systems of curves  $\mathcal{C} = \{C_1, \dots, C_n\}$  and  $\mathcal{D} = \{D_1, \dots, D_n\}$  on  $T_n$  define a Heegaard diagram of  $M$ , there exist two handlebodies  $U_n$  and  $U'_n$  of genus  $n$ , with  $\partial U_n = \partial U'_n = T_n$ , such that  $M = U_n \cup U'_n$ . Let now  $\mathcal{G}_n$  be the cyclic group of order  $n$  generated by the homeomorphism  $\rho_n$  on  $T_n$ . The action of  $\mathcal{G}_n$  on  $T_n$  extends to both the handlebodies  $U_n$  and  $U'_n$  (see [29]), and hence to the 3-manifold  $M$ . Let  $B_1$  (resp.  $B'_1$ ) be a disc properly embedded in  $U_n$  (resp. in  $U'_n$ ) such that  $\partial B_1 = C_1$  (resp.  $\partial B'_1 = D_1$ ). Since  $\rho_n(C_i) = C_{i+1}$  and  $\rho_n(D_i) = D_{i+1} \pmod{n}$ , the discs  $B_k = \rho_n^{k-1}(B_1)$  (resp.  $B'_k = \rho_n^{k-1}(B'_1)$ ), for  $k = 1, \dots, n$ , form a system of meridian discs for the handlebody  $U_n$  (resp.  $U'_n$ ). By arguments contained in [38], the quotients  $U_1 = U_n/\mathcal{G}_n$  and  $U'_1 = U'_n/\mathcal{G}_n$  are both handlebody orbifolds topologically homeomorphic to a genus one handlebody with one arc trivially embedded as its singular set with a cyclic isotropy group of order  $n$ . The intersection of these orbifolds is a 2-orbifold with two singular points of order  $n$ , which is topologically the torus  $T_1 = T_n/\mathcal{G}_n$ ; the curve  $C$  (resp.  $D$ ), which is the image via the quotient map of the curves  $C_i$  (resp. of the curves  $D_i$ ), is non-homotopically trivial in  $T_1$ . These curves, each of which is a fundamental system of curves in  $T_1$ , define a Heegaard diagram of  $M'$  (induced by  $H(a, b, c, 1, r, 0)$ ). The union of the orbifolds  $U_1$  and  $U'_1$  is a 3-orbifold topologically homeomorphic to  $M'$ , having a genus one 1-bridge knot  $K \subset M'$  as singular set of order  $n$ . Thus,  $M'$  is homeomorphic to  $M'/\mathcal{G}_n$  and hence  $M$  is the  $n$ -fold cyclic covering of  $M'$ , branched over  $K$ . Since the handlebody orbifolds and their gluing only depend on  $a, b, c, r$ , the same holds for the branching set  $K$ . The homeomorphism type of  $M'$  follows from Proposition 2 and Lemma 5.  $\square$

**Remark 4.** More generally, given two positive integers  $n$  and  $n'$  such that  $n'$  divides  $n$ , if  $(a, b, c, r, n, s)$  is admissible, then the Dunwoody manifold  $M(a, b, c, n, r, s)$  is the  $n/n'$ -fold cyclic covering of the manifold  $M' = M(a, b, c, n', r, s)$ , branched over an  $(n', 1)$ -knot in  $M'$ .

**Example 2.** The Dunwoody manifolds  $M(0, 0, 1, n, 0, 0)$ ,  $M(1, 0, 0, n, 1, 0)$  and  $M(0, 0, c, n, r, 0)$ , with  $c, r$  coprime, are  $n$ -fold cyclic coverings of the manifolds  $S^3$ ,

$\mathbf{S}^1 \times \mathbf{S}^2$  and  $L(c, r)$  respectively, branched over a trivial knot. In fact, these Dunwoody manifolds are the connected sum of  $n$  copies of  $\mathbf{S}^3$ ,  $\mathbf{S}^1 \times \mathbf{S}^2$  and  $L(c, r)$  respectively.

Let us consider now the class of the Dunwoody manifolds  $M_n = M(a, b, c, n, r, s)$  with  $p = \pm 1$  (and hence  $d$  odd) and  $s = -pq$ . Many examples of these manifolds appear in Table 1 of [6], where it was conjectured that they are  $n$ -fold cyclic coverings of  $\mathbf{S}^3$ , branched over suitable knots. The following corollary of Theorem 6 proves this conjecture.

**Corollary 7.** *Let  $\sigma_1 = (a, b, c, 1, r, 0)$  be an admissible 6-tuple with  $p_{\sigma_1} = \pm 1$  and  $s = -p_{\sigma_1}q_{\sigma_1}$ . Then the 6-tuple  $\sigma_n = (a, b, c, n, r, s)$  is admissible for each  $n > 1$  and the Dunwoody manifold  $M_n = M(a, b, c, n, r, s)$  is an  $n$ -fold cyclic coverings of  $\mathbf{S}^3$ , branched over a genus one 1-bridge knot  $K \subset \mathbf{S}^3$ , which is independent on  $n$ .*

*Proof.* Obviously  $(a, b, c, 1, r, s) = \sigma_1$ . Since  $\sigma_1$  is admissible, it satisfies (i'). This proves that  $\sigma_n$  satisfies (i'), for each  $n > 1$ . Since  $s = -p_{\sigma_1}q_{\sigma_1} = -p_{\sigma_n}q_{\sigma_n}$  and  $p_{\sigma_n} = p_{\sigma_1} = \pm 1$ , we obtain  $q_{\sigma_n} + sp_{\sigma_n} = 0$ , for each  $n > 1$ , which implies condition (ii) of Theorem 2 of [6], or equivalently (ii'). Moreover,  $d$  is odd, since  $[d]_2 = [2a + b + c]_2 = [b + c]_2 = [p_{\sigma_n}]_2 = [p_{\sigma_1}]_2 = 1$ . Thus, Lemma 3 proves that  $\sigma_n$  is admissible. The final result is then a direct consequence of Theorem 6.  $\square$

We point out that the above result has been independently obtained by H. J. Song and S. H. Kim in [32].

An interesting problem which naturally arises is that of characterizing the set  $\mathcal{K}$  of branching knots in  $\mathbf{S}^3$  involved in Corollary 7. The next theorem shows that it contains all 2-bridge knots. We recall that a 2-bridge knot is determined by two coprime integers  $\alpha$  and  $\beta$ , with  $\alpha > 0$  odd. The classification of 2-bridge knots and links has been obtained by Schubert in [30]. Since the 2-bridge knot of type  $(\alpha, \beta)$  is equivalent to the 2-bridge knot of type  $(\alpha, \alpha - \beta)$ , then  $\beta$  can be assumed to be even.

**Theorem 8.** *The 6-tuple  $\sigma_1 = (a, 0, 1, 1, r, 0)$  with  $(2a + 1, 2r) = 1$  is admissible. Moreover, if  $s = -q_{\sigma_1}$ , then the 6-tuple  $\sigma_n = (a, 0, 1, n, r, s)$  is admissible for each  $n > 1$  and the Dunwoody manifold  $M_n = M(a, 0, 1, n, r, s)$  is the  $n$ -fold cyclic covering of  $\mathbf{S}^3$ , branched over the 2-bridge knot of type  $(2a + 1, 2r)$ . Thus, all branched cyclic coverings of 2-bridge knots are Dunwoody manifolds.*

*Proof.* From  $(2a + 1, 2r) = 1$  it immediately follows that  $\sigma_1$  has a unique cycle in  $\mathcal{D}$ . Since  $d = 2a + 1$  is odd, Corollary 4 proves that  $\sigma_1$  is admissible. Since  $p_{\sigma_n} = p_{\sigma_1} = +1$ , all assumptions of Corollary 7 hold; hence  $\sigma_n$  is admissible for each  $n > 1$  and  $M_n$  is an  $n$ -fold cyclic covering of  $\mathbf{S}^3$ , branched over a knot  $K \subset \mathbf{S}^3$  which is independent on  $n$ . In order to determine this knot, we can restrict our attention to the case  $n = 2$ . Note that  $[s]_2 = [-q_{\sigma_1}]_2 = [b]_2 = 0$  and hence  $s$  is always even. Thus, in the case  $n = 2$  we can suppose  $s = 0$ . Let us consider now the genus two Heegaard diagram  $H(a, 0, 1, 2, r, 0)$ . The sequence of Singer moves [31] on this diagram, drawn

in Figures 3–10 and described in the Appendix of the paper, leads to the canonical genus one Heegaard diagram of the lens space  $L(2a + 1, 2r)$  (see Figure 10). Since the representation of lens spaces (including  $S^3$ ) as 2-fold branched coverings of  $S^3$  is unique [14], the result immediately holds.  $\square$

**Remark 5.** The Dunwoody manifold  $M(a, 0, 1, n, r, s)$  of Theorem 8 is homeomorphic to the Minkus manifold  $M_n(2a + 1, 2r)$  [21] and the Lins-Mandel manifold  $S(n, 2a + 1, 2r, 1)$  [19, 24].

An immediate consequence of Theorem 8 is:

**Corollary 9.** *The fundamental group of every branched cyclic covering of a 2-bridge knot admits a cyclic presentation which is geometric.*

**Remark 6.** In [21] is shown that the fundamental group of every branched cyclic covering of a 2-bridge knot admits a cyclic presentation, but without pointing out that this presentation is geometric.

About the set  $\mathcal{K}$  of knots in  $S^3$  involved in Corollary 7, we propose the following:

**Conjecture.** The set  $\mathcal{K}$  contains all torus knots.

If this conjecture is true, the set  $\mathcal{K}$  contains knots with an arbitrarily high number of bridges. Moreover, the conjecture implies that every branched cyclic covering of a torus knot admits a geometric cyclic presentation. The above conjecture is supported by several cases contained in Table 1 of [6] (see [32]). For example, the Dunwoody manifolds  $M(1, 2, 3, n, 4, 4)$  (resp.  $M(1, 3, 4, n, 5, 5)$ ) are the  $n$ -fold branched cyclic coverings of the 4-bridge torus knot  $K(4, 5)$  (resp. of the 5-bridge torus knot  $K(5, 6)$ ).

#### 4 Appendix

Now we show how to obtain, by means of Singer moves [31] on the genus two Heegaard diagram  $H(a, 0, 1, 2, r, 0)$  of Figure 3, the canonical genus one Heegaard diagram of the lens space  $L(2a + 1, 2r)$  of Figure 10. The result will be achieved by a sequence of exactly  $a + 4$  Singer moves: one of type ID,  $a + 2$  of type IC and the final one of type III.

Figure 3 shows the open Heegaard diagram  $H(a, 0, 1, 2, r, 0)$ . Note that, since  $s = 0$ , the cycle  $C'_1$  (resp.  $C'_2$ ) is glued with the cycle  $C''_1$  (resp.  $C''_2$ ). Let  $D_1$  (resp.  $D_2$ ) be the cycle of the Heegaard diagram corresponding to the arc  $e'$  (resp.  $e''$ ) coming out from the vertex  $v'$  of  $C'_1$  (resp.  $v''$  of  $C'_2$ ) labelled  $a + 1$ . Orient  $D_1$  (resp.  $D_2$ ) so that the arc  $e'$  (resp.  $e''$ ) is oriented from up to down (resp. from down to up). This orientation on  $D_2$  is opposite to the canonical one but, in this way, all the  $2a$  arcs connecting  $C'_1$  with  $C'_2$  are oriented from  $C'_1$  to  $C'_2$  and all the  $2a$  arcs connecting  $C''_1$  with  $C''_2$  are oriented from  $C''_2$  to  $C''_1$ . The cycle  $D_1$ , besides the arc  $e'$ , has two arcs for each  $k = 0, \dots, a - 1$ , one joining the vertex of  $C'_1$  labelled  $a + 1 - (1 + 2k)r$  with the vertex of  $C'_2$  labelled  $a + 1 + (1 + 2k)r$ , and the other one joining the vertex of  $C''_2$

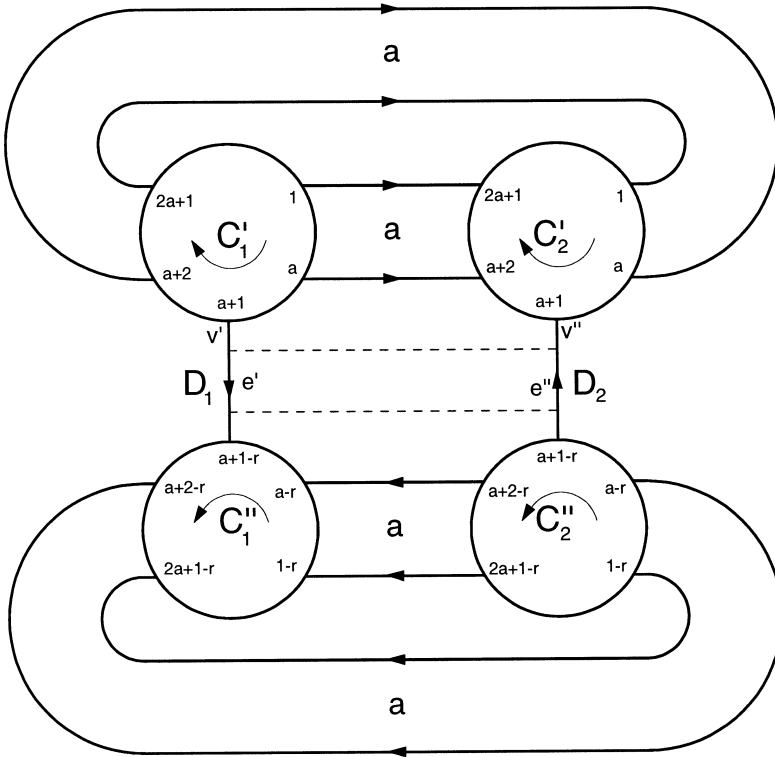

Fig. 3.

labelled  $a + 1 + (1 + 2k)r$  with the vertex of  $C''_1$  labelled  $a + 1 - (3 + 2k)r$ . The cycle  $D_2$ , besides the arc  $a_2$ , has two arcs for each  $k = 0, \dots, a - 1$ , one joining the vertex of  $C'_1$  labelled  $a + 1 - (2 + 2k)r$  with the vertex of  $C'_2$  labelled  $a + 1 + (2 + 2k)r$ , the other joining the vertex of  $C''_2$  labelled  $a + 1 + 2kr$  with the vertex of  $C''_1$  labelled  $a + 1 - (2 + 2k)r$ .

The first Singer move consists of replacing the curve  $D_2$  with the curve  $D'_2 = D_1 + D_2$  (move of type ID of [31]) obtained by isotopically approaching the arcs  $e'$  and  $e''$  until their intersection becomes a small arc and by removing the interior of this arc. The move is completed by shifting, with a small isotopy,  $D_1$  in  $D'_1$  so that it becomes disjoint from  $D'_2$ .

The resulting Heegaard diagram is drawn in Figure 4. The new  $2a + 1$  pairs of vertices obtained on  $C'_1, C''_1, C'_2, C''_2$  are labelled by simply adding a prime to the old label, while the  $4a + 2$  pairs of fixed vertices keep their old labelling. Note that each new vertex labelled  $j'$  is placed, in the cycles  $C'_1, C''_1, C'_2$  and  $C''_2$ , between the old vertices labelled  $j$  and  $j + 1$  respectively. The cycles  $C'_2$  and  $C''_2$  are no longer connected by any arc, while the cycles  $C'_1$  and  $C''_1$  are connected by a unique arc (belonging to  $D'_1$ ) joining the vertex labelled  $(a + 1)'$  of  $C'_1$  with the vertex labelled  $(a + 1 - r)'$  of  $C''_1$ . All the  $3a$  arcs connecting  $C'_1$  and  $C'_2$  are oriented from  $C'_1$  to

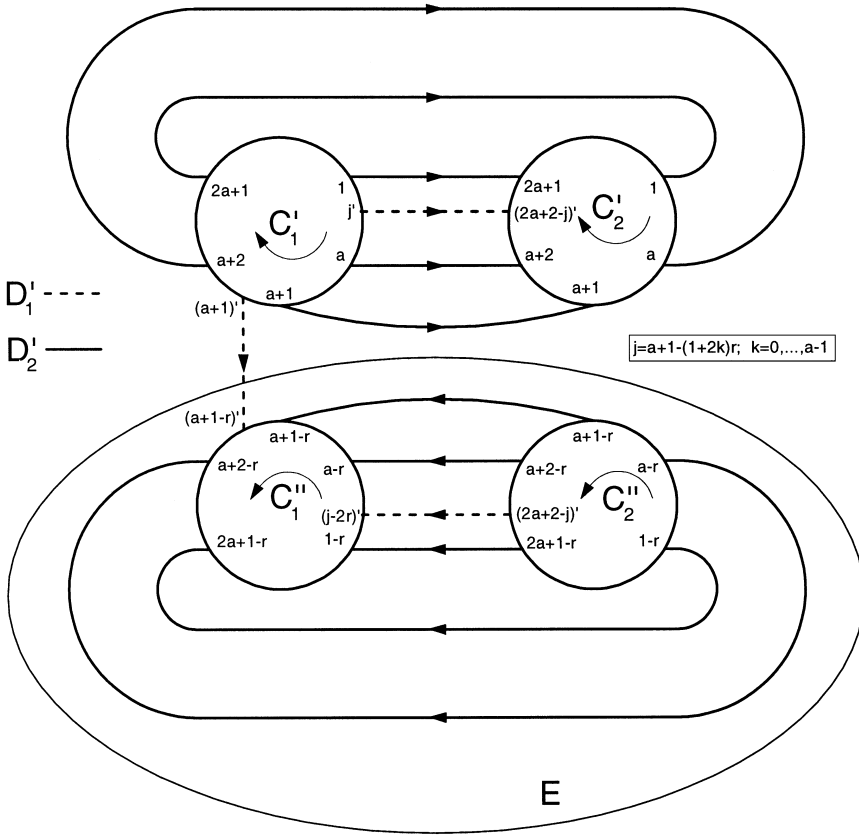

Fig. 4.

$C'_2$  and all the  $3a$  arcs which now connect  $C'_1$  with  $C'_2$  are oriented from  $C'_2$  to  $C'_1$ . The cycle  $D'_2$  contains exactly  $4a + 2$  arcs; more precisely, for each  $i = 1, \dots, 2a + 1$ , it has one arc joining the vertex labelled  $i$  of  $C'_1$  with the vertex labelled  $2a + 2 - i$  of  $C'_2$  and one arc joining the vertex labelled  $i$  of  $C'_2$  with the vertex labelled  $2a + 2 - 2r - i$  of  $C'_2$ . The cycle  $D'_1$  is a copy of the cycle  $D_1$  and hence it contains  $2a + 1$  arcs. One of these arcs connects  $C'_1$  with  $C''_1$ ; moreover, for each  $k = 0, \dots, a - 1$ ,  $D'_1$  has one arc joining the vertex of  $C'_1$  labelled  $(a + 1 - (1 + 2k)r)'$  with the vertex of  $C'_2$  labelled  $(a + 1 + (1 + 2k)r)'$  and one arc joining the vertex of  $C'_2$  labelled  $(a + 1 + (1 + 2k)r)'$  with the vertex of  $C''_1$  labelled  $(a + 1 - (3 + 2k)r)'$ .

Now, apply to the diagram a Singer move of type IC, cutting along the cycle  $E$  (drawn in Figure 4) containing  $C'_1$  and  $C'_2$  and gluing the curve  $C''_2$  of the resulting disc with  $C'_2$ .

The new Heegaard diagram obtained in this way shown in Figure 5. It contains the new cycles  $E'$  and  $E''$ , which are copies of the cutting cycle  $E$ . These cycles replace  $C'_2$  and  $C''_2$  and they both have a unique vertex ( $w'$  and  $w''$  respectively). The cycle  $E'$

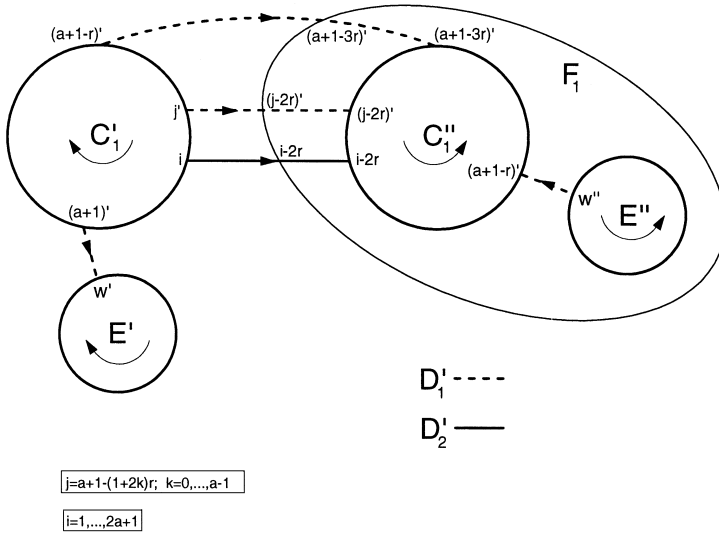

Fig. 5.

(resp.  $E''$ ) is connected with  $C'_1$  (resp. with  $C''_1$ ) by an arc joining  $w'$  (resp.  $w''$ ) with the vertex labelled  $(a + 1)'$  (resp.  $(a + 1 - r)'$ ), oriented as in Figure 5. The cycles  $C'_1$  and  $C''_1$  are joined by  $3a + 1$  arcs, all oriented from  $C'_1$  to  $C''_1$ ;  $2a + 1$  of them belong to  $D'_2$  and the other  $a$  belong to  $D'_1$ . More precisely, for each  $i = 1, \dots, 2a + 1$ , there is an arc of  $D'_2$  joining the vertex labelled  $i$  of  $C'_1$  with the vertex labelled  $i - 2r$  of  $C''_1$ ; while, for each  $k = 0, \dots, a - 1$ , there is an arc of  $D'_1$  joining the vertex labelled  $(a + 1 - (1 + 2k)r)'$  of  $C'_1$  with the vertex labelled  $(a + 1 - (3 + 2k)r)'$  of  $C''_1$ .

Apply again a Singer move of type IC, cutting along the cycle  $F_1$  (drawn in Figure 5) containing  $C''_1$  and  $E''$  and gluing the curve  $C''_1$  of the resulting disc with  $C'_1$ .

The resulting Heegaard diagram is shown in Figure 6. It contains the new cycles  $F'_1$  and  $F''_1$ , which are copies of the cutting cycle  $F_1$ . These cycles replace  $C'_1$  and  $C''_1$  and they both have one vertex less. It is easy to see that the cycle  $D'_2$  has exactly the same  $2a + 1$  arcs connecting  $F'_1$  and  $F''_1$ , all oriented from  $F'_1$  to  $F''_1$ ; if the labelling of the vertices of  $F'_1$  and  $F''_1$  is induced by the labelling of  $F_1$  shown in Figure 5, these arcs join pairs of vertices with the same labelling of the previous step. The cycle  $D'_1$  instead has one arc less than in the previous step. In fact, it has  $a - 1$  arcs, connecting  $F'_1$  and  $F''_1$ , all oriented from  $F'_1$  to  $F''_1$  and joining the vertex labelled  $(a + 1 - (1 + 2k)r)'$  of  $F'_1$  with the vertex labelled  $(a + 1 - (3 + 2k)r)'$  of  $F''_1$ , for  $k = 1, \dots, a - 1$ .

Now, apply again a Singer move of type IC, cutting along the cycle  $F_2$  (drawn in Figure 6) containing  $F''_1$  and  $E''$  and gluing the curve  $F''_1$  of the resulting disc with  $F'_1$ .

The new Heegaard diagram only differs from the previous one for containing one arc less in the cycle  $D'_1$ . By inductive application of Singer moves of type IC, cutting along the cycle  $F_h$  (drawn in Figure 7) containing  $F''_{h-1}$  and  $E''$  and gluing the curve  $F''_{h-1}$  of the resulting disc with  $F'_{h-1}$ , we obtain, for  $h = a$ , the situation shown in

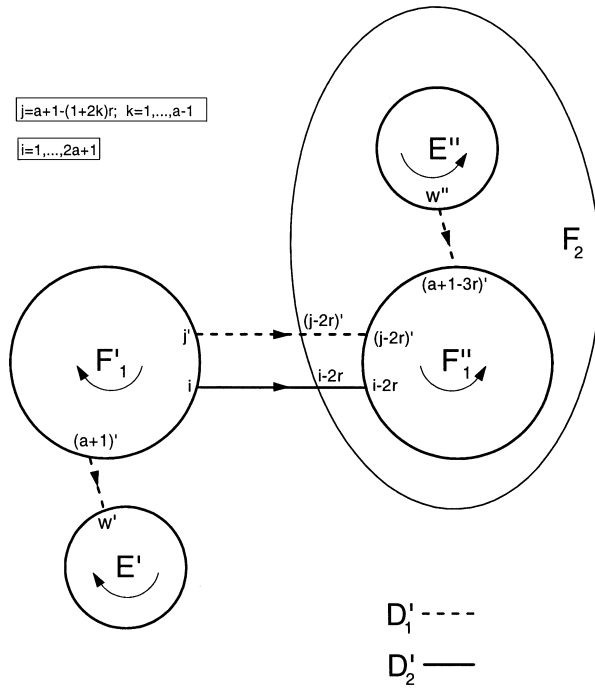

Fig. 6.

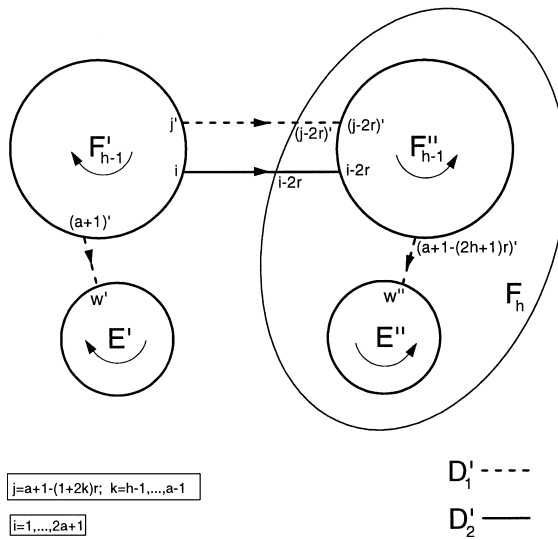

Fig. 7.

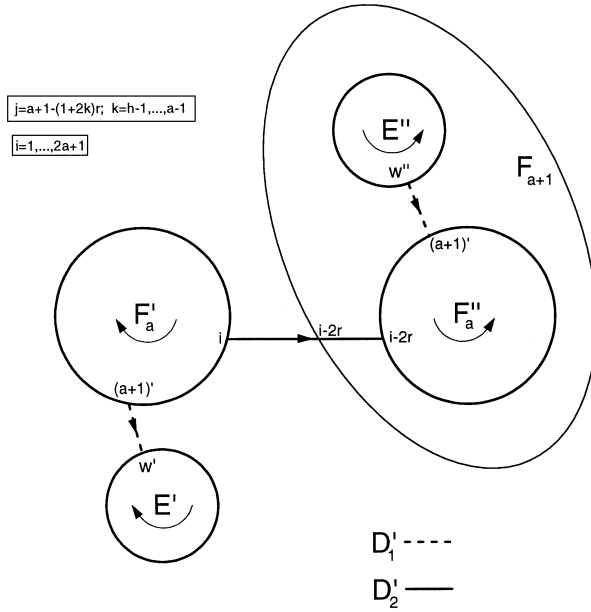

Fig. 8.

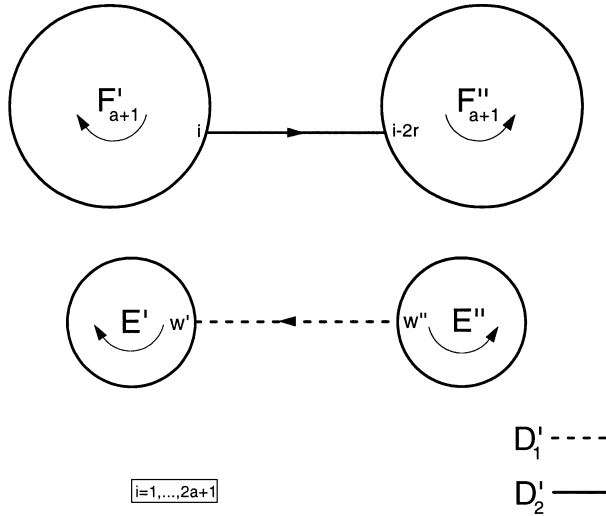

Fig. 9.

Figure 8, where the cycle  $D'_1$  contains only two arcs, none of which connects  $F'_a$  with  $F''_a$ .

After the move of type IC corresponding to  $h = a + 1$ , we obtain the situation of Figure 9 in which the Heegaard diagram contains a pair of complementary handles



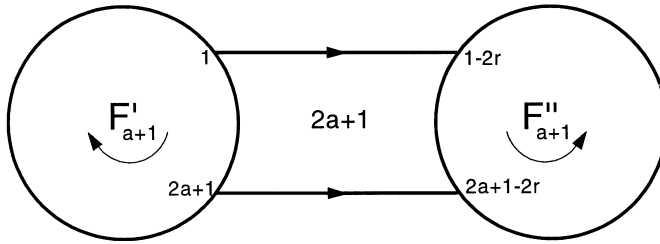

Fig. 10.

given by the pair of cycles  $E', E''$  and by the cycle  $D'_1$ , composed by a unique arc connecting  $E'$  with  $E''$ . The deletion of this pair of complementary handles (Singer move of type III) leads to the genus one Heegaard diagram drawn in Figure 10, which is the canonical Heegaard diagram of the lens space  $L(2a + 1, 2r)$ .

## References

- [1] Bandieri, P., Kim, A. C., Mulazzani, M.: On the cyclic coverings of the knot  $5_2$ . Proc. Edinb. Math. Soc. **42** (1999), 575–587
- [2] Berge, J.: The knots in  $D^2 \times S^1$  with non-trivial Dehn surgery yielding  $D^2 \times S^1$ . Topology Appl. **38** (1991), 1–19
- [3] Cavicchioli, A., Hegenbarth, F., Kim, A. C.: A geometric study of Sieradsky groups. Algebra Colloq. **5** (1998), 203–217
- [4] Cavicchioli, A., Hegenbarth, F., Repovš, D.: On manifold spines and cyclic presentations of groups. In: Knot theory. Proceedings of the mini-semester, Warsaw, Poland, July 13–August 17, 1995. Warszawa: Polish Academy of Sciences, Institute of Mathematics, Banach Cent. Publ. **42** (1998), 49–56
- [5] Doll, H.: A generalized bridge number for links in 3-manifold. Math. Ann. **294** (1992), 701–717
- [6] Dunwoody, M. J.: Cyclic presentations and 3-manifolds. In: Proc. Inter. Conf., Groups-Korea '94. Walter de Gruyter, Berlin-New York, 1995, 47–55
- [7] Gabai, D.: Surgery on knots in solid tori. Topology **28** (1989), 1–6
- [8] Gabai, D.: 1-bridge braids in solid tori. Topology Appl. **37** (1990), 221–235
- [9] Grasselli, L.: 3-manifold spines and bijoins. Rev. Mat. Univ. Complutense Madr. **3** (1990), 165–179
- [10] Hayashi, C.: Genus one 1-bridge positions for the trivial knot and cabled knots. Math. Proc. Camb. Philos. Soc. **125** (1999), 53–65
- [11] Helling, H., Kim, A. C., Mennicke, J. L.: Some honey-combs in hyperbolic 3-space. Commun. Algebra **23** (1995), 5169–5206
- [12] Helling, H., Kim, A. C., Mennicke, J. L.: A geometric study of Fibonacci groups. J. Lie Theory **8** (1998), 1–23
- [13] Hempel, J.: 3-manifolds. Annals of Math. Studies, vol. 86. Princeton University Press, Princeton, N.J. 1976
- [14] Hodgson, C., Rubinstein, J. H.: Involutions and isotopies of lens spaces. In: Knot

- theory and manifolds – Vancouver 1983. Lect. Notes Math. 1144, Springer (1985), 60–96
- [15] Johnson, D. L.: Topics in the theory of group presentations. London Math. Soc. Lect. Note Ser., vol. 42. Cambridge Univ. Press, Cambridge, U.K. 1980
- [16] Kim, A. C.: On the Fibonacci group and related topics. *Contemp. Math.* **184** (1995), 231–235
- [17] Kim, G., Kim, Y., Vesnin, A.: The knot  $5_2$  and cyclically presented groups. *J. Korean Math. Soc.* **35** (1998), 961–980
- [18] Kim, A. C., Vesnin, A.: On a class of cyclically presented groups. To appear in: Proc. Inter. Conf., Groups-Korea '98. Walter de Gruyter, Berlin-New York 2000
- [19] Lins, S., Mandel, A.: Graph-encoded 3-manifolds. *Discrete Math.* **57** (1985), 261–284
- [20] Maclachlan, C., Reid, A. W.: Generalised Fibonacci manifolds. *Transform. Groups* **2** (1997), 165–182
- [21] Minkus, J.: The branched cyclic coverings of 2 bridge knots and links. *Mem. Amer. Math. Soc.* **35** Nr. 255 (1982), 1–68
- [22] Montesinos, J. M.: Representing 3-manifolds by a universal branching set. *Math. Proc. Camb. Philos. Soc.* **94** (1983), 109–123
- [23] Morimoto, K., Sakuma, M.: On unknotting tunnels for knots. *Math. Ann.* **289** (1991), 143–167
- [24] Mulazzani, M.: All Lins-Mandel spaces are branched cyclic coverings of  $S^3$ . *J. Knot Theory Ramifications* **5** (1996), 239–263
- [25] Neuwirth, L.: An algorithm for the construction of 3-manifolds from 2-complexes. *Proc. Camb. Philos. Soc.* **64** (1968), 603–613
- [26] Osborne, R. P., Stevens, R. S.: Group presentations corresponding to spines of 3-manifolds I. *Amer. J. Math.* **96** (1974), 454–471
- [27] Osborne, R. P., Stevens, R. S.: Group presentations corresponding to spines of 3-manifolds II. *Trans. Amer. Math. Soc.* **234** (1977), 213–243
- [28] Osborne, R. P., Stevens, R. S.: Group presentations corresponding to spines of 3-manifolds III. *Trans. Amer. Math. Soc.* **234** (1977), 245–251
- [29] Reni, M., Zimmermann, B.: Extending finite group actions from surfaces to handlebodies. *Proc. Amer. Math. Soc.* **124** (1996), 2877–2887
- [30] Schubert, H.: Knoten mit zwei Brücken. *Math. Z.* **65** (1956), 133–170
- [31] Singer, J.: Three-dimensional manifolds and their Heegaard diagrams. *Trans. Amer. Math. Soc.* **35** (1933), 88–111
- [32] Song, H. J., Kim, S. H.: Dunwoody 3-manifolds and  $(1, 1)$ -decomposable knots. Preprint, 1999
- [33] Stevens, R. S.: Classification of 3-manifolds with certain spines. *Trans. Amer. Math. Soc.* **205** (1975), 151–166
- [34] Vesnin, A., Kim, A. C.: The fractional Fibonacci groups and manifolds. *Sib. Math. J.* **39** (1998), 655–664
- [35] Wu, Y-Q.: Incompressibility of surfaces in surgered 3-manifold. *Topology* **31** (1992), 271–279
- [36] Wu, Y-Q.:  $\partial$ -reducing Dehn surgeries and 1-bridge-knots. *Math. Ann.* **295** (1992), 319–331
- [37] Wu, Y-Q.: Incompressible surfaces and Dehn surgery on 1-bridge knots in handlebody. *Math. Proc. Camb. Philos. Soc.* **120** (1996), 687–696
- [38] Zimmermann, B.: Genus actions of finite groups on 3-manifolds. *Mich. Math. J.* **43** (1996), 593–610

Received November 22, 1999

Luigi Grasselli, Department of Sciences and Methods for Engineering, University of Modena and Reggio Emilia, 42100 Reggio Emilia, Italy  
grasselli.luigi@unimo.it

Michele Mulazzani, Department of Mathematics, University of Bologna, I-40127 Bologna, Italy, and C.I.R.A.M., Bologna, Italy  
mulazza@dm.unibo.it